

WKM Model 320F Floating Ball Valve

Installation, Operation, and Maintenance Manual



All the information contained in this manual is the exclusive property of Cameron. Any reproduction or use of the calculations, drawings, photographs, procedures or instructions, either expressed or implied, is forbidden without the written permission of Cameron or its authorized agent.

Release 04

May 2022

TC-003001-41/ Rev 04

Table of Contents

| | |
|---|----|
| Bill of Materials | 5 |
| Scope..... | 8 |
| Nameplate Information | 9 |
| Storage | 10 |
| Valves Delivered by WKM..... | 10 |
| Lifting and Handling Guidelines | 10 |
| Installation and Operation Instructions | 11 |
| Before Installation Safety Information | 11 |
| Installation | 11 |
| Field Pressure Testing | 13 |
| Operation | 14 |
| Maintenance Procedures..... | 15 |
| Troubleshooting..... | 16 |

The procedures included in this book are to be performed in conjunction with the requirements and recommendations outlined in API Specifications. Any repairs to the equipment covered by this book should be done by an authorized Cameron service representative. Cameron will not be responsible for loss or expense resulting from any failure of equipment or any damage to any property or death or injury to any person resulting in whole or in part from repairs performed by other than authorized Cameron personnel. Such unauthorized repairs shall also serve to terminate any contractual or other warranty, if any, on the equipment and may also result in equipment no longer meeting applicable requirements.

File copies of this manual are maintained. Revisions and/or additions will be made as deemed necessary by Cameron. The drawings in this book are not drawn to scale, but the dimensions shown are accurate.

Bill of Materials

320F Standard Wrench-Operated Floating Ball Valve (2in 600 shown – see parts list in table 1)

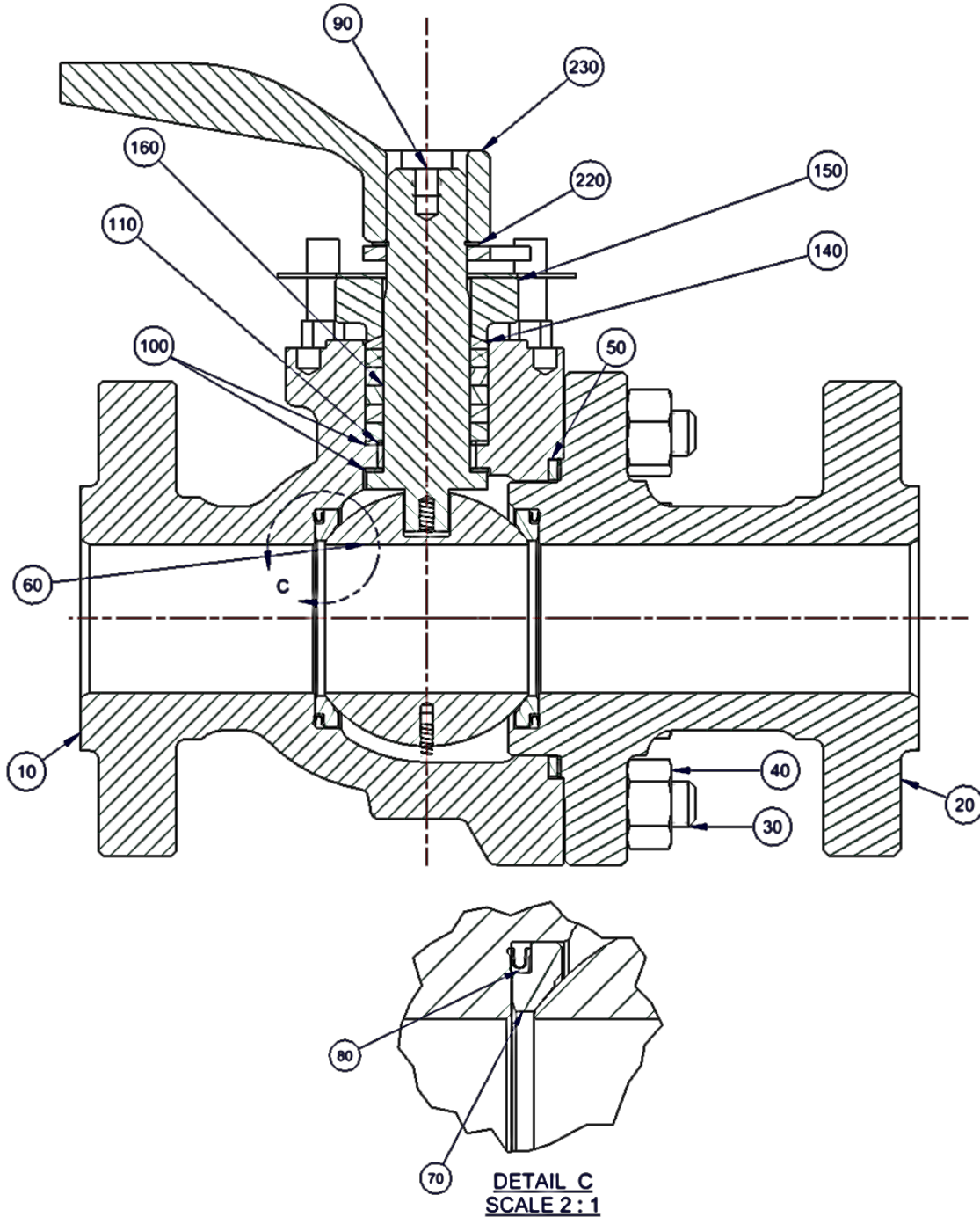

Figure 1 - Detail Section 1

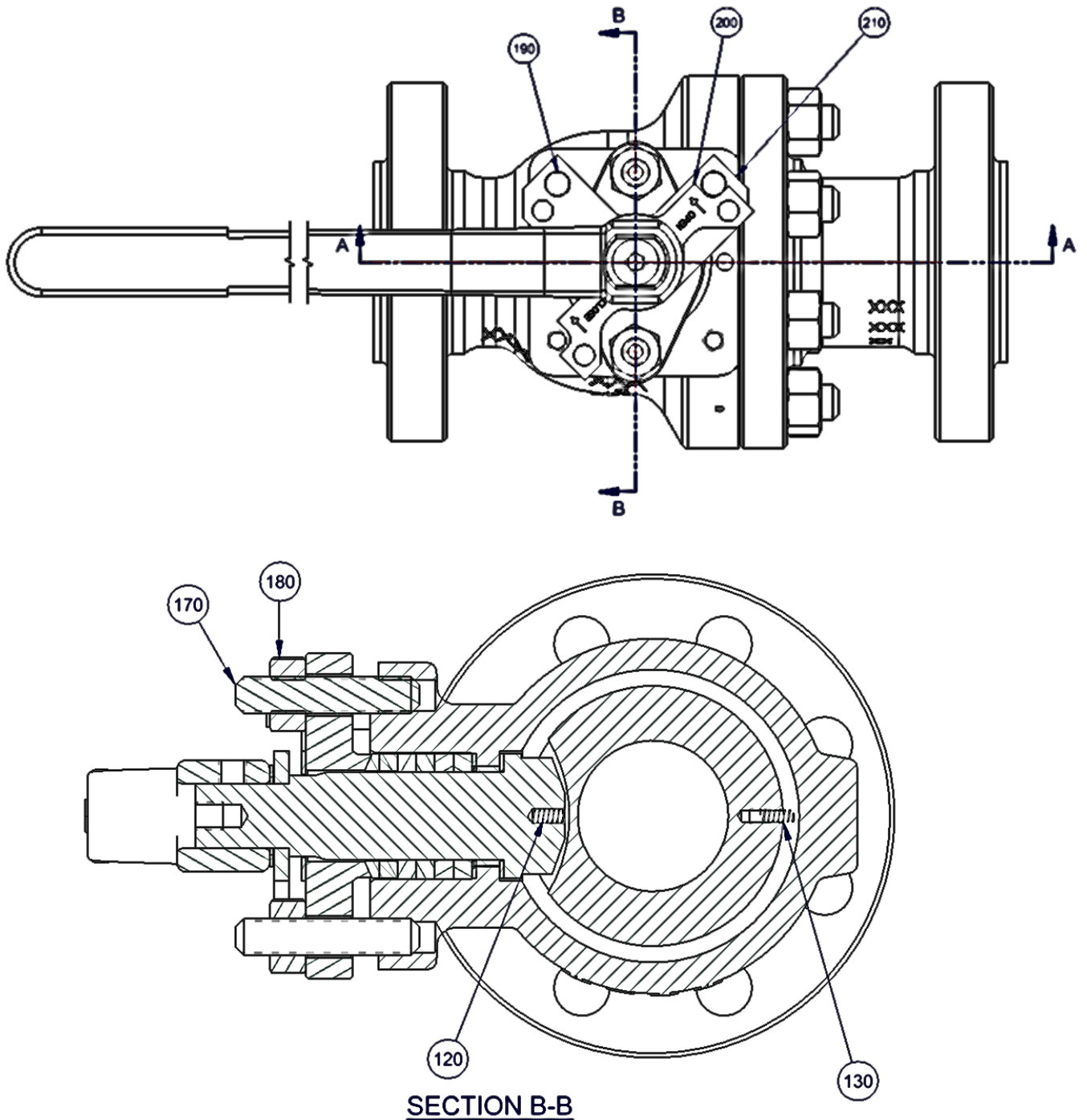

Figure 2 - Detail Section 2

Table 1 – Parts List for Standard Wrench-Operated Valve

| ITEM | QTY | DESCRIPTION |
|------|-----|----------------------------|
| 10 | 1 | BODY |
| 20 | 1 | TAILPIECE |
| 30 | 8 | BODY STUDS |
| 40 | 8 | BODY NUTS |
| 50 | 1 | BODY GASKET |
| 60 | 1 | BALL |
| 70 | 2 | SEAT RING |
| 80 | 2 | SEAT LIP SEAL |
| 90 | 1 | STEM |
| 100 | 2 | STEM THRUST WASHER |
| 110 | 1 | STEM BEARING |
| 120 | 1 | GROUNDING SPRING STEM/BALL |
| 130 | 1 | GROUNDING SPRING BALL/BODY |
| 140 | 1 | PACKING FOLLOWER |
| 150 | 1 | PACKING PLATE |
| 160 | 1 | STEM PACKING |
| 170 | 2 | PACKING PLATE STUD |
| 180 | 2 | PACKING PLATE NUT |
| 190 | 2 | STOP PIN |
| 200 | 1 | STOP PLATE |
| 210 | 1 | LOCK PLATE |
| 220 | 1 | SNAP RING |
| 230 | 1 | HANDLE |
| 240 | 1 | NAMEPLATE (NOT SHOWN) |

**2FP 600 wrench-operated configuration shown. Customer assembly drawings (available upon request) will include details for the particular size/class/configuration chosen.*

Scope

The WKM 320F ball valve is designed to meet the latest industry requirements utilizing a variety of drivetrain materials, including A105 & 316SS. Patent-pending self-relieving seats that eliminate pressure trap, low-emission adjustable stem packing, and API 607 7th edition fire test certification are among the many standard features. Seats can be supplied in Delrin, RTFE, or PEEK with PTFE or graphite fugitive emission-grade packing. The 320F is offered in carbon and stainless steel in the sizes and classes shown below in table 2.

Table 2 - 320F Series Floating Ball Valve Availability

| Valve Availability | | | |
|--------------------|-----|-----|-----|
| Valve Size/Class | 150 | 300 | 600 |
| 1FP | X | X | X |
| 1-1/2RP | X | X | X |
| 1-1/2FP | X | X | X |
| 2RP | X | X | X |
| 2FP | X | X | X |
| 3RP | X | X | X |
| 3FP | X | X | X |
| 4RP | X | X | X |
| 4FP | X | X | X |
| 6RP | X | X | X |
| 6FP | X | X | X |
| 8RP | X | X | X |

**All valves are built with trim selection that the customer requires. Contact a WKM representative for proper trim selection for the required application.*

Nameplate Information

The valve information, including trim, is clearly identified on the valve nameplate that is permanently affixed on the valve. Figure 3 shows a standard valve nameplate. Table 3 details the information stamped on the nameplate.

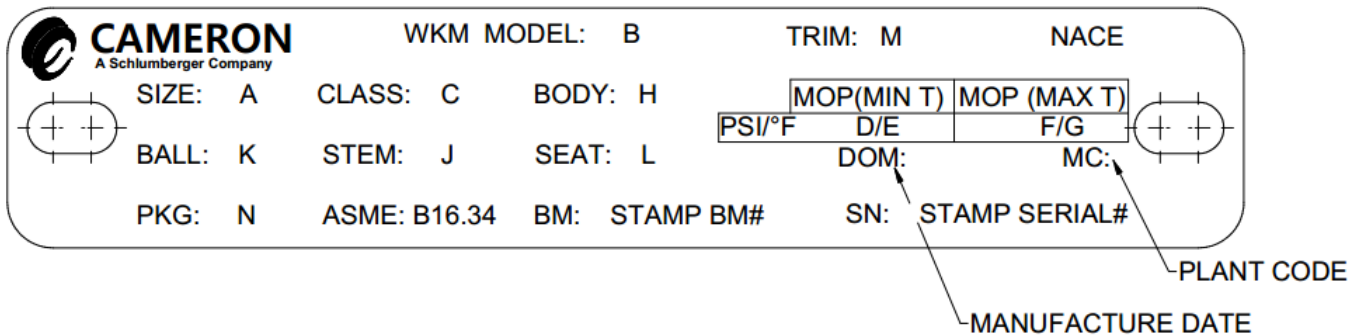

Figure 3 - Standard Cameron 320F Tag

Table 3 - 320F Tag Information

| Item | Preprint | Stamp |
|------|------------------|--|
| A | SIZE | If full bore, size is the nominal bore size If reduced bore, size is end size x bore through ball x end size |
| B | WKM MODEL | Valve Model |
| C | CLASS | Valve Class Designation as defined per API 6D |
| D | MOP (or MAWP) | Maximum Operating Pressure (or Maximum Allowable Working Pressure); the maximum working pressure of the valve at 100°F |
| E | MIN T | Minimum operating temperature range |
| F | MOP (or MAWP) | Maximum Operating Pressure (or Maximum Allowable Working Pressure); the maximum working pressure of the valve at its maximum temperature limit |
| G | MAX T | Maximum operating temperature range |
| H | BODY** | Body Material Symbol |
| J | STEM** | Stem Material Symbol |
| K | BALL** | Ball Material Symbol |
| L | SEAT** | Seat Material Symbol |
| M | TRIM | Valve Trim Code |
| N | PKG** | Packing Material Symbol |

*Serial # is most important data for obtaining replacement parts

**Consult a WKM Representative for material's symbol correspondence

Storage

Valves Delivered by WKM

After valves are assembled and tested, they are placed in the full open position, flange seal surfaces and bores are greased and end protectors are installed. This will provide adequate protection for indoor storage. Extended outdoor storage or storage in particularly harsh environments (i.e. an uncovered marine atmosphere) requires periodic inspection and the addition of a corrosion inhibitor. Contact your WKM representative for extended storage guidelines. Valves should only be stored in the fully open or fully closed position to prevent seat distortion.

Lifting and Handling Guidelines

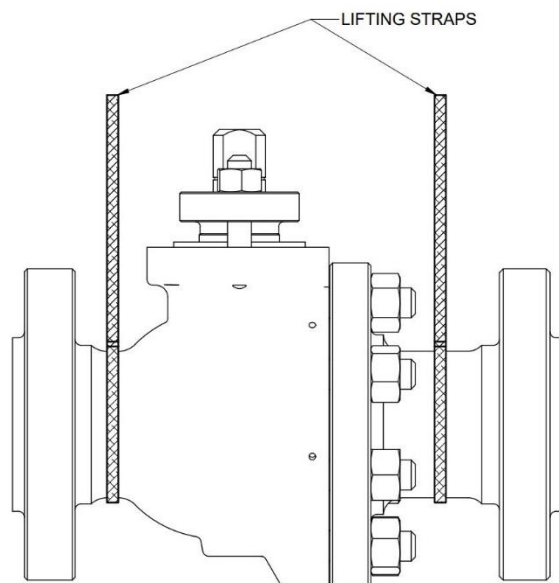

Figure 4: Lifting Guideline

Always use suitable lifting equipment and supports. Make sure that devices (including but not limited to lifting cranes, chains, or slings) are in good condition and properly rated for the weight of the valve plus any mounted actuation components before lifting loads.

Ensure that staff who take part in the lifting process have sufficient training for the job. Participate in a pre-job safety meeting or lift plan prior to any operation. Establish red zones (no-go zones) prior to the lift.

Always secure the lifting to the valve body, never to the actuator; otherwise, the stem/shaft may be damaged.

Before attaching the load, be aware of the weight of the load to be lifted and locate the center of gravity to prepare for how the load will behave and to ensure balanced lifting. Lift the valve in the position in which it is to be installed. Lift and move the load at an even pace to avoid swaying. Never leave the load suspended in mid-air.

Make sure that the valve and actuator (if equipped) are correctly in place prior to detaching the supports. Make sure the load does not fall over when you undo the supports.

Refer to detail lifting drawings (available upon request) for specific weight and center of gravity.

Installation and Operation Instructions

Before Installation Safety Information

Valves shall be operated and maintained strictly in accordance with these procedures. Operation or maintenance outside of these procedures constitutes abuse of the product and voids all warranty claims.

When special operation is required, a formal written request to the company must be made for approval to operate in this manner if warranty and product liability are to be maintained.

Before any work is performed on a valve, personnel working on the valve must obtain the proper work permits required by their employer. Personnel shall always use safety precautions set forth by law and the regulations required by their employer. Personnel shall also be aware that any venting or draining of fluids from the valve shall be done in accordance with the safety and environmental procedures enforced at the particular location where the valve is installed.

The maintenance personnel doing the repairs shall be well trained and familiar with all information contained in this manual.

The valves shall be appropriately used for the intended purpose. Any safety or protection devices on the valve shall not be permanently removed or altered unless written approval is received from a WKM representative.

Transport, unpacking, lifting, and connections to the different types of systems (electric, pneumatic, hydraulic systems, etc.) shall be made by expert and qualified personnel.

Should any difficulties or abnormalities arise that cannot be solved by the technician, contact a WKM representative.

Any servicing not covered by these instructions must be made by an authorized service center, after preliminary approval has been given by a WKM representative.

Installation

Before installation, ensure that all external components and sealing surfaces of connection flanges were not damaged during transportation. Clearly identify the valve through its nameplate, check its weight with the packing list or relevant documents, and then place it on a horizontal surface using suitable handling equipment.

Handling equipment must be provided which is appropriate for the total weight of the package. Pay particular attention that slings do not damage the gear or actuator, if equipped.

Do not use lifting lugs or eyes provided on the gear or actuator, if present, to lift the entire assembly.

To avoid the ingress of debris or sand into the ball and seat area, the protective covers should not be removed until the valve is ready to be installed in the line. When the valve is ready to be installed in the line, remove the protective plastic or wooden flange protectors.

During installation, the valve must be fully open and the line sections between which the valve will be installed must be aligned, cleaned, and correctly spaced. Should the valve be closed, the exposed face of the ball must be protected with grease or other anti-adhesive product.

320F ball valves may be installed in any position with flow from either direction. However, for best service life there is a preferred vertical or horizontal position to maximize sealing and minimize the accumulation of sediment. In the vertical position, it is preferred to have the upstream pressure from above so the weight of the ball will assist the pressure in sealing. With the valve in a horizontal position, it is preferred to have the stem lying horizontal (i.e. toward the viewer). During operation, flow will act as a siphon and minimize retention of sediment.

When handling or installing a valve, keep the valve in the full open position whenever possible to prevent foreign object damage to the ball. When installing the valve, allow for possible deformations caused by the expansion of the line. The valve must not support the line. Avoid any strain in the valve body.

CAUTION: Do not overload the valve beyond the design piping loads stated in the requirements.

Use studs, nuts, and raised face gaskets or ring joints for the given size and class that conform to ASME B16.5. Alternately tighten the studs using a cross pattern method, several times, following the procedure recommended by ASME PCC-1-2010 "Guidelines for Pressure Boundary Bolted Flange Joint Assembly" or gasket manufacturer specification.

CAUTION: While all 320F floating ball valves have self-relieving seats as standard equipment, it is recommended that appropriate safeguards be put into place to prevent exceeding the pressure/temperature limits given by the manufacturer.

Field Pressure Testing

When field pressure testing is required, follow these procedures to minimize any damage that could occur to the sealing surfaces of the ball and seats:

1. Ensure that the test fluids contain corrosion inhibitors that are compatible with the valve seat and seal material.
2. The valve should be in the fully open position when the injection of test fluid begins. This will allow any pipeline debris to be flushed through the valve bore and out of the piping and not damage the seat, seal, or ball.
3. Once the piping system has been purged of debris and the system has been filled completely with the test fluid, the ball should then be turned to partially closed position (approximately 10-30° from the fully open position), to allow test fluid into the body cavity of the valve.
4. If performing line shell testing, the valve shall be in half open position. During a shell test is the only time when the valve should ever be left in a position other than fully open or closed. After shell test, return to the fully open or fully closed position for normal operation. The maximum shell test line pressure can be 1-1/2 times the valve maximum cold working pressure. If performing seat testing, make sure the valve is fully closed. The maximum pressure for seat testing is the maximum cold working pressure.
5. Upon completion of pressure testing all test fluids should be purged from the valve.

WARNING: If the ball is left for an extended period or is continually operated in any position other than fully open or fully closed, excessive wear to the seat and ball will occur. This will result in premature valve failure.

CAUTION: If the seats are tested to a higher pressure than the maximum cold working pressure they may become permanently damaged. If a higher test pressure is desired contact a WKM representative for details.

Operation

320F series ball valves only work in the fully closed or fully open position; these valves work for on/off service only.

WARNING: These valves shall never be operated partially open or partially closed. Throttling (partial opening) or “pinching” flow may cause non-uniform wear on seats and ball over the sealing surfaces where it is exposed to the flow line, preventing tight shut-off.

To close the valve, turn gear hand wheel clockwise until it stops; to open the valve turn the gear hand wheel counter-clockwise until it stops.

All the wrench operated valves have the wrench levers aligned along with valve through bore when opened and perpendicular with the through bore when closed.

All gear operated valves have the gear indicator aligned with the valve through bore when opened and perpendicular with the through bore when closed. The gear also has “OPEN” and “CLOSE” markings.

While opening or closing, the ball must reseat; this reseating torque is higher than the run torque. Turn the hand wheel until the gear has a positive stop.

If the valve is operated by a power actuator, carefully read the actuator operation manual.

CAUTION: The end stops have been shop set to assure the correct 90 degree rotation from the fully open to fully closed position. Do not change their adjustment. If the valve is not correctly resealed at the end of opening or closing, the ball and the seats can quickly be damaged when exposed to flow pressure, preventing tight shut-off.

These valves can be operated by one person. It is recommended that no extensions be used for operating the valve. Using an extension or power tool to operate the valve voids all warranty and claims, and may result in failure.

Should maintenance be required, obtain the part number from the valve assembly nameplate and contact your WKM representative.

Maintenance Procedures

Under normal working conditions, 320F ball valves are designed for lengthy, reliable service with very little maintenance.

The only preventive maintenance recommended is to periodically inspect the valve for leaks around the stem or actuator. Should a leak be noticed, the following procedure may be followed to adjust the packing:

1. With the proper size wrench, tighten each of the two packing adjustment fasteners in a clockwise direction.
2. Tighten each fastener an equal amount. Use the minimum torque required to stop the leak, not to exceed the maximum torque value specified in Table 4 below.
3. Table 4 gives torque values that will affect a seal when the packing set is in good condition. Torque values above this indicate that packing is worn and needs replacement. Excessive tightening will cause an unacceptable increase in valve stem torque.

Table 4 - Packing Fastener Torque Values

| Torque Values for 320F Packing Fasteners | | | | |
|--|-----------------|------------------|--------------|------------------|
| VALVE BORE SIZE & CLASS | STUD & NUT SIZE | WRENCH HEAD SIZE | PTFE PACKING | GRAPHITE PACKING |
| 1" 150# | 5/16 – 18 UNC | 9/16 | 4 FT-LBS. | 13 FT-LBS. |
| 1" 300# – 1.5" 150# | 3/8 – 16 UNC | 11/16 | 8 FT-LBS. | 29 FT-LBS. |
| 1.5" 300# – 2" 150# | 1/2 – 13 UNC | 7/8 | 17 FT-LBS. | 39 FT-LBS. |
| 2" 300# – 3" 150# | | 7/8 | 20 FT-LBS. | 47 FT-LBS. |
| 3" 300# – 4" 150# | 5/8 – 11 UNC | 1-1/16 | 40 FT-LBS. | 89 FT-LBS. |
| 4" 300# – 6" 150# | 3/4 – 10 UNC | 1-1/4 | 60 FT-LBS. | 140 FT-LBS. |
| 6" 300# – 6" 600# | 7/8 – 9 UNC | 1-7/16 | 105 FT-LBS. | 248 FT-LBS. |

Troubleshooting

Table 5 - Troubleshooting Chart

| ISSUE | PROBABLE CAUSE | REMEDY |
|--|---|---|
| Will not open or close | Iced up due to restricted flow or low temperature | Flush out with warm material |
| Hard to operate | <ul style="list-style-type: none"> a) Accumulation or solidification of material in valve body b) Corrosion between stem and valve body c) Operator not installed properly | <ul style="list-style-type: none"> a) Flush valve to remove material from body b) Apply penetrating oil around stem. If problem is not solved disassemble valve and polish stem |
| Will not seal properly | <ul style="list-style-type: none"> a) Worn or damaged seats and/or ball b) Foreign matter between seat and ball c) Operator stops not properly set | <ul style="list-style-type: none"> a) Replace worn parts (Requires valve removal and disassembly) b) Operate several times to wipe clean c) Adjust stops to proper setting |
| Valve leaking between body and tailpiece | <ul style="list-style-type: none"> a) Leaking tailpiece gasket b) Tailpiece and body are not tightened properly | <ul style="list-style-type: none"> a) Replace gasket (Requires valve removal and disassembly) b) Tighten parts to specified torque |
| Stem packing is leaking | <ul style="list-style-type: none"> a) Loose stem packing b) Worn or damaged packing c) Operator/Actuator is misaligned, creating a side load on stem | <ul style="list-style-type: none"> a) Adjust stem packing fasteners b) Replace stem packing c) Adjust bracket/operator to remove side load |